

# **Autonomous Robot Control Circuit**

## **- Theory of Operation -**

**Written by:**

Colin Mantay

Revision 1.07-06-04

Copyright © 2004 by Colin Mantay

No part of this document may be copied, reproduced, stored electronically, distributed or modified without explicit written authorization from the author. While reasonable care has been exercised with respect to accuracy, the author assumes no responsibility for errors, omissions or suitability of contents for any applications. Nor does the author assume any liability for any damages resulting from the use of the information contained in this document. It is the reader's responsibility to determine if use, sale or manufacture of any device that incorporates information contained in this documents infringes any patents, copyrights or other rights. Use at your own risk.

## Introduction

This document will look at the construction of the electronics section of a skid-steering edge-sensing autonomous robot whose sole purpose is to randomly navigate a flat, elevated driving surface without falling off. The ideas presented in this document are geared towards people who already have some experience in building basic remote controlled robots and some experience in electronics. It will be assumed that the reader has a basic understanding of electronic components, wiring diagrams, and terminology.

## Section 1: Robot Navigation

The navigation technique used by the robot is quite simple; drive forward until it finds an edge. Once it finds an edge it will respond by backing away, re-orienting itself (so it doesn't drive straight into the same edge) and go forward again. With a skid-steer setup it becomes quite easy to control forward, reverse and steering functions.

To perform the forward function it's as simple as applying voltage to the motors so that they both turn in a forward direction. The same goes for reverse except that the polarity to the motors is reversed. To steer the robot it's a matter of making one motor go forward and the opposite motor go in reverse. This causes the chassis to spin in clockwise or counter-clockwise direction around an axis that is located between the two drive wheels.

To perform the function of backing away from an edge and turning around is a matter of making both motors go in reverse, once the robot has backed up a significant distance, make one motor go forward therefore turning the robot around, then making the second motor go forward so the robot can drive off to the next edge. This whole operation can be accomplished using two simple re-settable timer circuits.

Two timer circuits could be set up so that while they were active the motors would turn in reverse, then once the timer became inactive (timed out) the motor would go forward. An edge-sensing device could then be set up to reset the timers forcing the motors to reverse and cause the robot to back away from an edge. If the two timers were set up to have different time limits then that would cause the robot to turn as one motor started turning forward before the other.

For example: If Timer1 was connected to the left motor and had a delay of 1 second and Timer2 was connected to the right motor and had a delay of 1.5 seconds. Once the robot reached an edge, both timers would become active causing the robot to reverse for one second. Timer1 would then time out and the left motor would go forward while the right motor stayed in reverse. The robot would then turn clockwise for half a second until Timer2 timed out and the right motor went forward as well causing the whole robot to move forward.

## Section 2: RC Timer Circuit.

The schematic in Figure 1 shows a basic resistor-capacitor (RC) charging circuit. Since the circuit operation is the same regardless of component value or supply voltage, components have not been given values. Assuming the power to the circuit has been turned off for a while, the capacitor (C1) will have no voltage across it, therefore the point Vc will read 0V when measured.

The instant the power is switched on or connected to the circuit, regardless of the power supply voltage, a current (illustrated by arrow labeled Ia) will flow through the resistor (R1) and C1. C1 will then begin to charge.

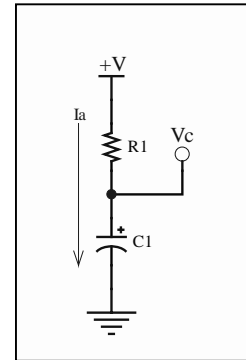

Figure 1 - RC circuit

The rate at which C1 charges is dependant on the current flowing through it, the higher the current the faster the charge. The current that will charge C1 will start off at a maximum and will taper off to no current once C1 is fully charged. The maximum current can easily be calculated using Ohm's law.

Because the initial voltage of C1 is 0V, the full voltage of the power supply is across R1 therefore the maximum current will be:

$$I_{max} = V_s/R1.$$

The two graphs in Figure 2 show the voltage on C1 and the current through the RC network. The dotted lines at the top of the graph illustrate the maximum values. For the first graph the maximum voltage on C1 is limited by Vs and in the second graph the maximum current is limited by R1.

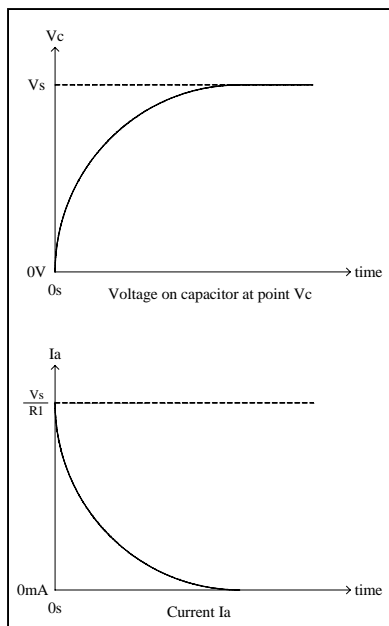

Figure 2 - RC charging graphs

This charging effect could be used in conjunction with a voltage-controlled switch that could be off when power was applied, but then turn on once the capacitor has charged to a certain voltage. The simplest voltage controlled switches available are the diode and transistor.

To operate a diode or transistor there is a minimum voltage, or forward voltage that must be met before the device will start to conduct current. By adding a diode and a transistor to the circuit an RC timed switch can be constructed.

The typical forward voltage for a diode and transistor is 0.65V. This voltage can be measured between the anode and cathode of a diode and the base and

emitter of a transistor. If both a diode and transistor were added to the circuit, as shown in Figure 3, then the combined forward voltage of the diode and transistor would be about 1.3V. In this case the voltage on C1 would only reach 1.3V because once the diode and transistor were both switched on, the current flow would effectively be diverted from the capacitor into the diode and transistor. The capacitor would then stop charging after only attaining a voltage of 1.3V.

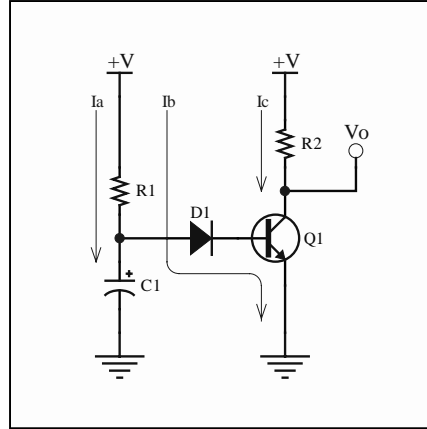

Figure 3 - RC circuit with transistor and diode

In the case of the circuit in Figure 3 when the power was first switched on current Ia would start to flow and charge the capacitor. Currents Ib and Ic would be zero. The voltage at the output point (Vo) would be measured as +V because of the collector resistor R2. Once the capacitor has charged to 1.3V, D1 and Q1 will be forward biased and current Ib will start to flow. Because D1 and Q1 have very low resistance the majority of current will flow through them and only enough current will flow through C1 to keep it charged at 1.3V.

Because of the base current in Q1, a collector current will flow as well. The collector current (marked Ic) flows through a collector resistor (R2). The current in R2 produces a voltage drop across R2 causing the point Vo to read zero volts. It can be seen that while the C1 is charging, the output would read +V (HIGH) and as soon as the capacitor has reached 1.3V the output drops to zero volts (LOW). This is the operation of a simple RC timer circuit.

## Section 3: Output Section

The entire motor control circuit is designed around a Quad Half H-Bridge Driver IC. The most common part numbers for this IC are L293D and SN754410. They both have the same pin out as illustrated in Figure 4. The main function of the IC is to convert low voltage, low current logic signals to high voltage, high current signals to directly drive a motor. The most common way of connecting a motor to this IC is directly across two of the output pins, meaning that the positive lead of a motor would be connected to output 1Y or 3Y and the negative lead of the motor would be connected to the respective output pin 2Y or 4Y.

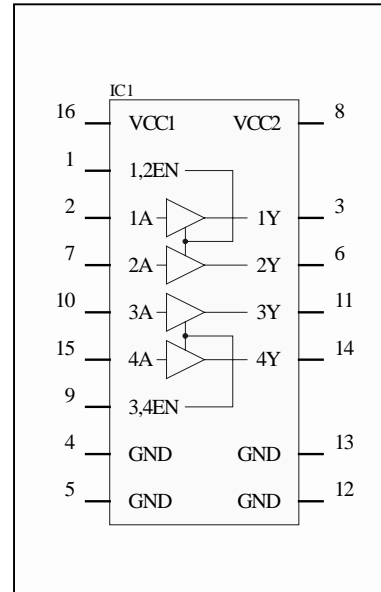

Figure 4 – H-Bridge IC pinout

By applying a positive voltage to the input pin 1A or 3A and by connecting input pin 2A or 4A to ground the motor will spin forward. If the inputs were reversed (1A or 3A LOW and 2A or 4A HIGH) the motor would spin in the reverse direction. In order to make the IC function properly the remainder of the pins must be connected as well.

The two VCC pins (VCC1 and VCC2) must be connected to supply voltages. VCC1 is connected to the logic supply voltage which is the same power supply that any logic level devices are connected, which is typically +5V. VCC2 is the motor supply voltage, which can be anything up to the IC's maximum rated voltage, which is typically +36V. The four ground pins must be connected to a good ground connection. Because the ground connections are also used as a heat sink for the IC it is a good idea to make the ground connections using heavier copper wire to help dissipate the heat generated by the device.

The two enable pins (1,2EN and 3,4EN) allow pairs of Half-H drivers to be individually enabled. By forcing the enable pins HIGH it allows the pair of Half-H drivers to output. When the enable pin is LOW the pair of drivers is disabled and regardless of the input to the drivers the output will be zero. The enable pins will be used later to provide a 5 second power-on delay that is required for autonomous entries in most robot games events.

It can be noted that the Half-H Bridge needs two inputs to control the direction of the motor and that the two inputs must be opposite of each other (complementary), meaning that when one input was HIGH then the other input would have to be LOW. In order to use one of these ICs with the RC

timer circuit proposed earlier, the output of the RC timer could be connected to one of the Half-H drivers and some form of inverter would be required to provide a complementary signal for the corresponding Half-H driver.

Figure 5 shows the first of two types of inverters that will be used in this project. The first inverter is designed around a PNP transistor. The input of the inverter is located at point A and the output of the inverter is point Y. When the input of the inverter is LOW it forward biases the transistor and current  $I_b$  is allowed to flow. Because there is a base current flowing through the transistor the collector current  $I_c$  is allowed to flow. The current  $I_c$  causes a voltage to appear across  $R_2$  and the output of the inverter is HIGH.

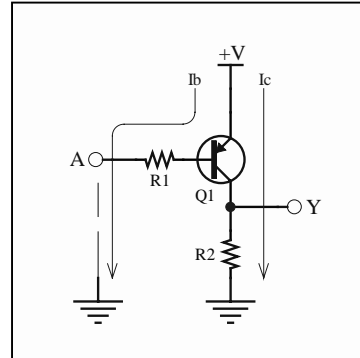

Figure 5 - PNP inverter

When the input to the inverter is HIGH current  $I_b$  cannot flow, therefore current  $I_c$  will not flow either allowing  $R_2$  to pull the output to ground giving a LOW output.

Figure 6 shows the second inverter, which is designed around a NPN transistor. The theory works the same way as the first inverter except

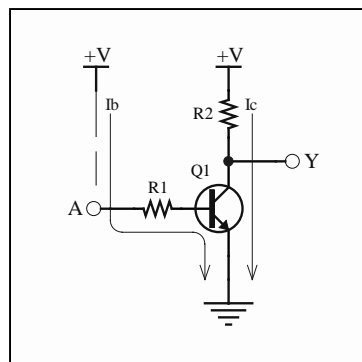

Figure 6 - NPN inverter

everything is reversed. When the input (point A) is HIGH the transistor is forward biased and current  $I_b$  can flow allowing collector current  $I_c$  to flow. Once again, because of current  $I_c$  a voltage appears across  $R_2$  but this time the output is LOW. When the input to the inverter is LOW current  $I_b$  will not flow; current  $I_c$  will not flow and the resistor will pull the output HIGH.

By connecting the two inverters back-to-back two complementary outputs can be created that can be used to drive the quad Half-H driver IC.

Figure 7 shows how the inverters are connected together, then to the motor control IC. The schematic shown in Figure 7 is half of the output section that will be used in the final design of the control circuit.

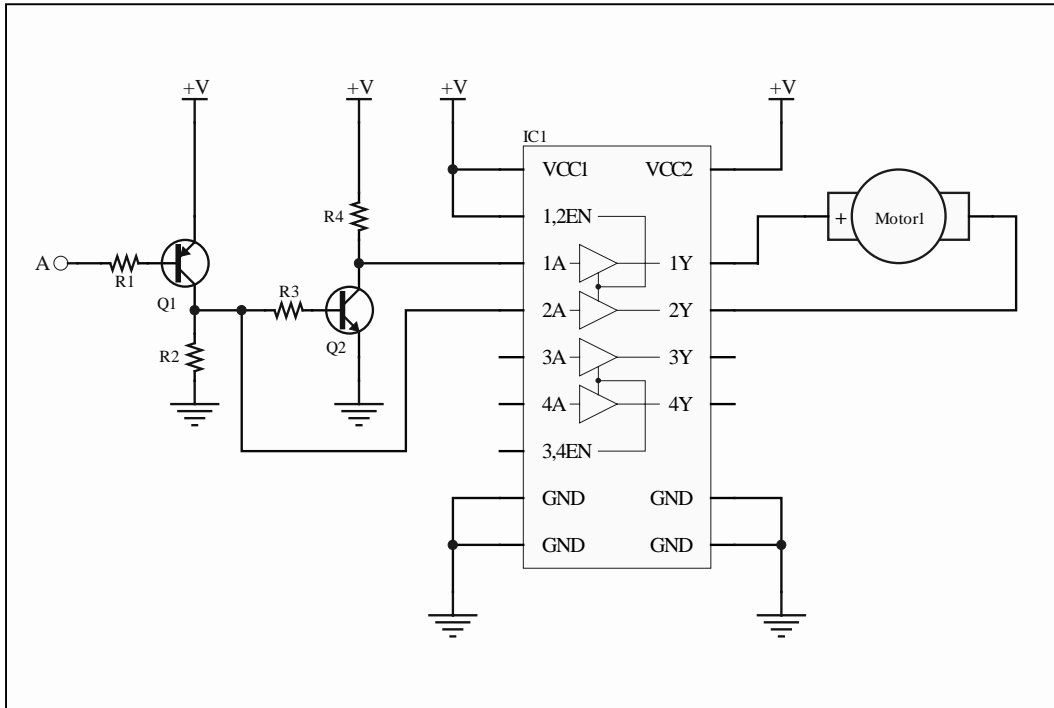

Figure 7 – Inverters and motor connected to Half-H driver IC

## Section 4: Input Section

In order for the edge sensors to control the motor direction some sort of input section is required to instantaneously control the voltage on the capacitor in the RC timer circuit. By using active LOW sensors, meaning that the sensor's output goes LOW when an edge is detected, it becomes very easy to reset the timer when the robot encounters an edge while it's traveling forward.

By simply connecting a diode to the capacitor the capacitor will be shorted to ground when an edge is detected and the timing cycle will re-start causing the robot's motor to momentarily go in reverse. The purpose of the diode is to isolate the capacitors should two timer circuits, with different charge rates, be connected together. Figure 8 shows the modified RC Timer circuit with the forward-edge detect input.

There is a possibility that the robot could wind up in a corner and while backing up would turn and drive backwards off the driving surface. By adding a reverse edge detector this problem is avoided. By using a transistor the RC timer capacitor could be charged virtually instantaneously causing the robot to drive forward again preventing it from backing over an edge. Figure 9 illustrates the addition of the transistorized reverse edge detect input.

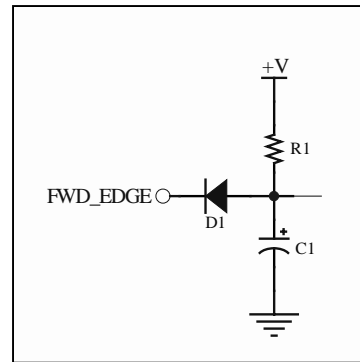

Figure 8 - RC Timer with front edge input

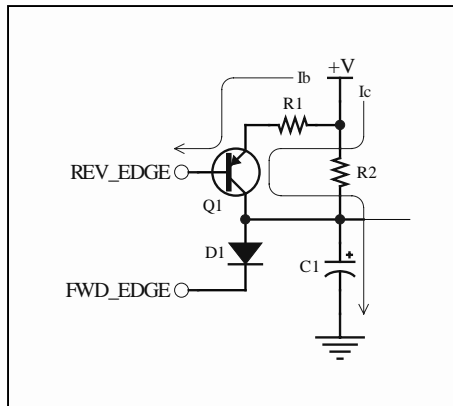

Figure 9 - RC Timer with both inputs

When the rear edge detector goes low it will cause Q1 to become forward biased and current  $I_b$  will flow causing current  $I_c$  to flow as well. R1 is included to protect the transistor from excessive current draw. By selecting a value for R1 approximately 1000 times smaller than the value of R2 when Q1 is switched on the current flowing through C1 will be as if it were shorted to +V as compared to the low charging current provided by R2. C1 will charge to the required 1.3V 1000 times faster than it would normally

thereby making the switch from reverse to forward seem instantaneous.

As long as the robot was at the edge of the driving surface the input(s) will remain low causing the robot to go in reverse. As soon as the robot has cleared the offending edge the corresponding input will return HIGH and C1 will begin to charge through R2. Once C1 has reached the nominal 1.3V the corresponding motor will go forward once again.

## Section 5: Power-on delay

In order to satisfy the requirements of a 5 second power-on delay implemented in the rules of most autonomous robot games events another RC timer circuit will be added and connected to the enable pins of the quad Half-H bridge driver IC. The timer is reset by a push-button switch that can be held down during the power-on of the robot and released once the start signal is given. The schematic for the power-on timer is given in Figure 10.

The power-on timer functions the same way as the motor control timer. R1 is added so the timer's exact duration can be fine-tuned to exactly 5 seconds. As long as the switch is held down the capacitor is prevented from charging. Once the switch is released the capacitor will begin to charge. Once it has reached 1.3V Q1 will switch on in turn switching on Q2 allowing current to flow through R4 creating a HIGH signal on the output of the power-on timer. While the reset switch is held, or while the capacitor is charging, R4 pulls the output LOW and disables the output from the quad Half-H bridge driver IC.

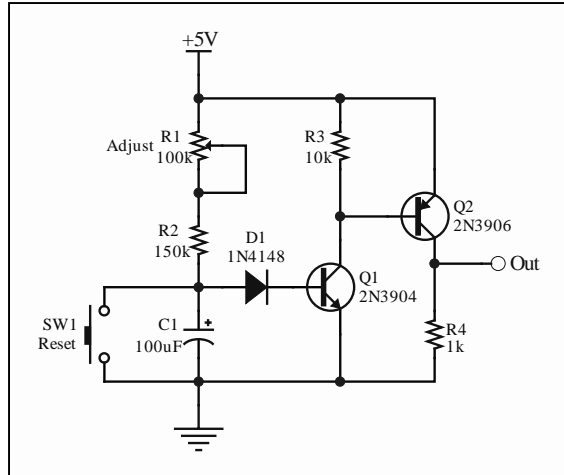

**Figure 10 - Power-on timer schematic**

## Section 6: Putting it all together

The completed motor control schematic can be found on the last page of this document. It consists of one power-on reset timer connected to the enable inputs of the quad Half-H bridge driver IC, two RC timer circuits, one for controlling the left motor and one for controlling the right motor, two inverter circuits per RC timer to provide complementary signals for the H-Bridge, a quad Half-H Bridge Driver IC and motors. Both motor control RC circuits have potentiometers to adjust the charging rate of the capacitor. This adjustment can be used to control how the robot performs its reverse-and-turn function.

